



Build Your Own Turbine

Materials for Each Tower:



1 - 24" Length PVC pipe



1 - 2" Length PVC pipe



6 - 6" Length PVC pipe



3 - PVC T-joints
(one with a drilled hole)



5 - PVC elbow (90°) fittings

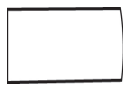

1 - PVC coupler

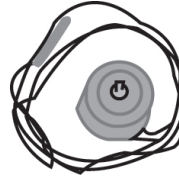

1 - Generator with 4' of wire

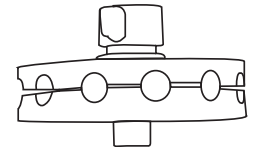

1 - 12 Hole crimping hub
(Purchase from Kidwind.org)

Constructing the Base

You will need: 4 - Elbow fittings, 3 - PVC T-joints, 6 - 6" length PVC pipe

1. Put aside the T-joint with the drilled hole and two 6" lengths of PVC pipe.
2. Using the remaining materials, follow the diagram on the right to construct the two sides of the turbine base.
3. Connect the two sides of the base using the remaining 6" lengths of PVC and the T-joint with the hole. The drilled hole should be pointing toward the ground.

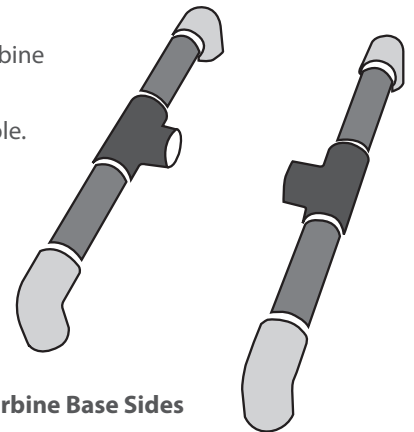

Turbine Base Sides

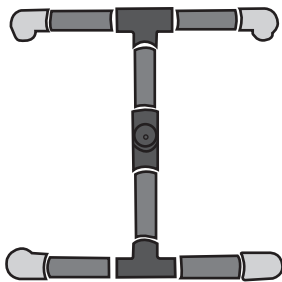

Connected Turbine Base

Constructing the Nacelle

You will need: 1 - PVC elbow, 1 - 2" length PVC pipe, 1 - PVC coupler, 1 - Generator with 4' of wire, duct tape (not included in kit)

1. Cut a piece of duct tape so it is about 18" long and 1/2" wide. Wrap the duct tape around the outside of the generator. This will help the generator fit securely into the PVC coupler.
2. Connect the PVC coupler, 2" length of PVC pipe, and PVC elbow as illustrated below. This is your nacelle.
3. Insert the wires attached to the generator through the nacelle. They should come out of the PVC elbow fitting.
4. Insert the motor into the coupler. It should fit very snugly. If it is too loose you can add more tape. If it is too tight you can remove some tape. (Tip: You may want to tape the wires down inside the nacelle to prevent students from breaking them if they pull too hard on the wires.)
5. Make sure the generator is straight and not too far in. If it is not straight it will cause the hub and blades to wobble while spinning.

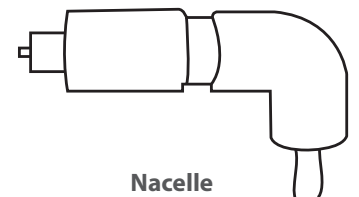

Nacelle

Connecting the Tower:

You will need: 1 – 24" Length of PVC, the constructed base, the constructed nacelle

1. Thread the generator wires through the PVC tower, then through the hole in the T-joint at the base.
2. Fit the tower into the base.
3. Fit the nacelle onto the top of the tower.

Note: If you feel the turbine is loose, wrap masking tape around the ends of the pieces until they fit snugly in the joints.

Adding the Hub and Blades:

You will need: 1 – 12 Hole crimping hub, the constructed tower, blades

1. Attach the hub to the nacelle by pressing it onto the generator's drive shaft.
2. Turn the knob on the front of the hub to loosen the two hub sides. Do not turn the knob too far or the hub will separate completely.
3. Place the blades into the slots. Tighten the hub to hold the blades in place.

Converting from a Basic Turbine to a Geared Turbine:

You will need: 1- Geared assembly, constructed turbine

1. Remove the hub, basic generator, and wires from the nacelle.
2. Thread the geared assembly wires through the nacelle, tower, and out of the T-joint at the base.
3. Fit the geared assembly into the PVC coupler. It should fit snugly.

Note: The hub on the geared assembly does not come off. Students will need to insert their blades into the hub on the geared assembly.

