

---

# PRIMARY ENERGY ACTIVITIES

---

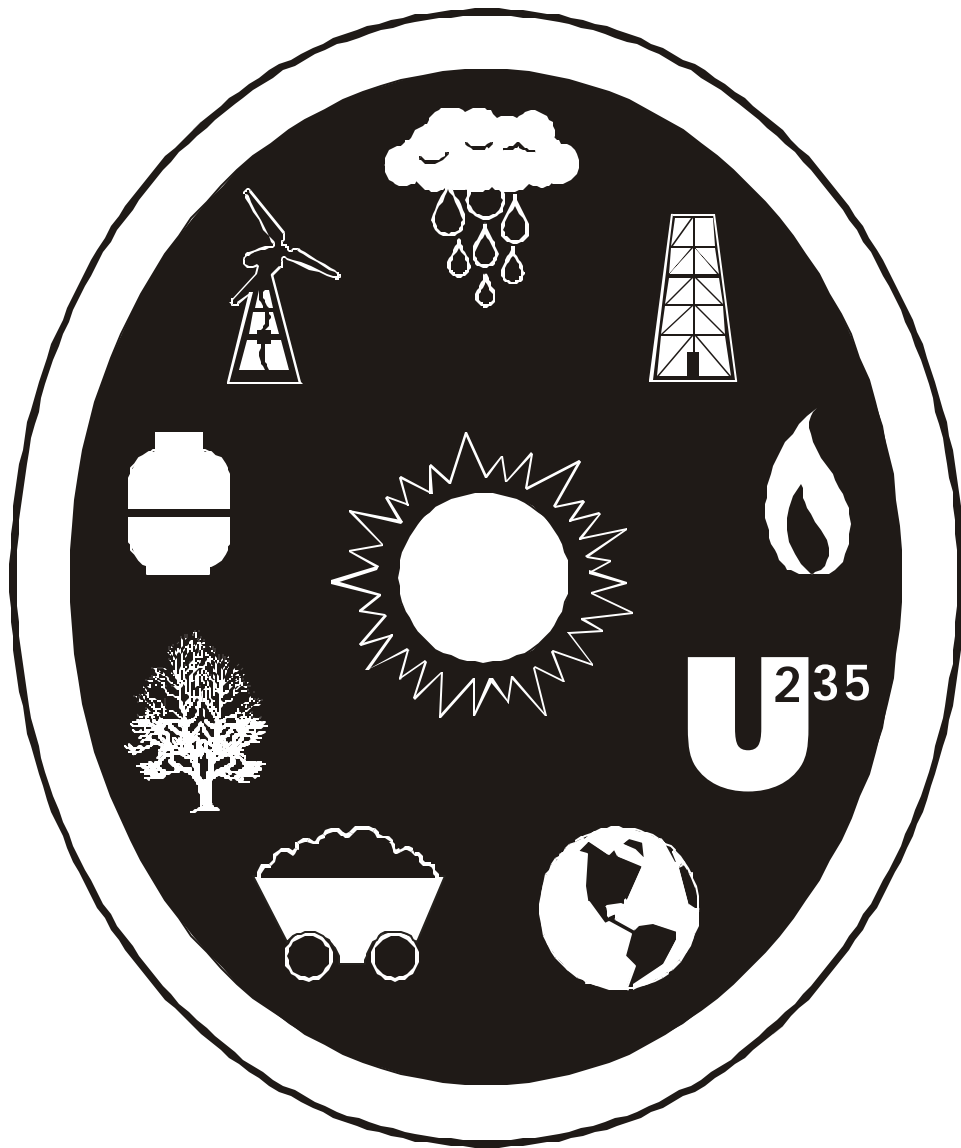

This workbook belongs to: \_\_\_\_\_

# ENERGY CROSSWORD

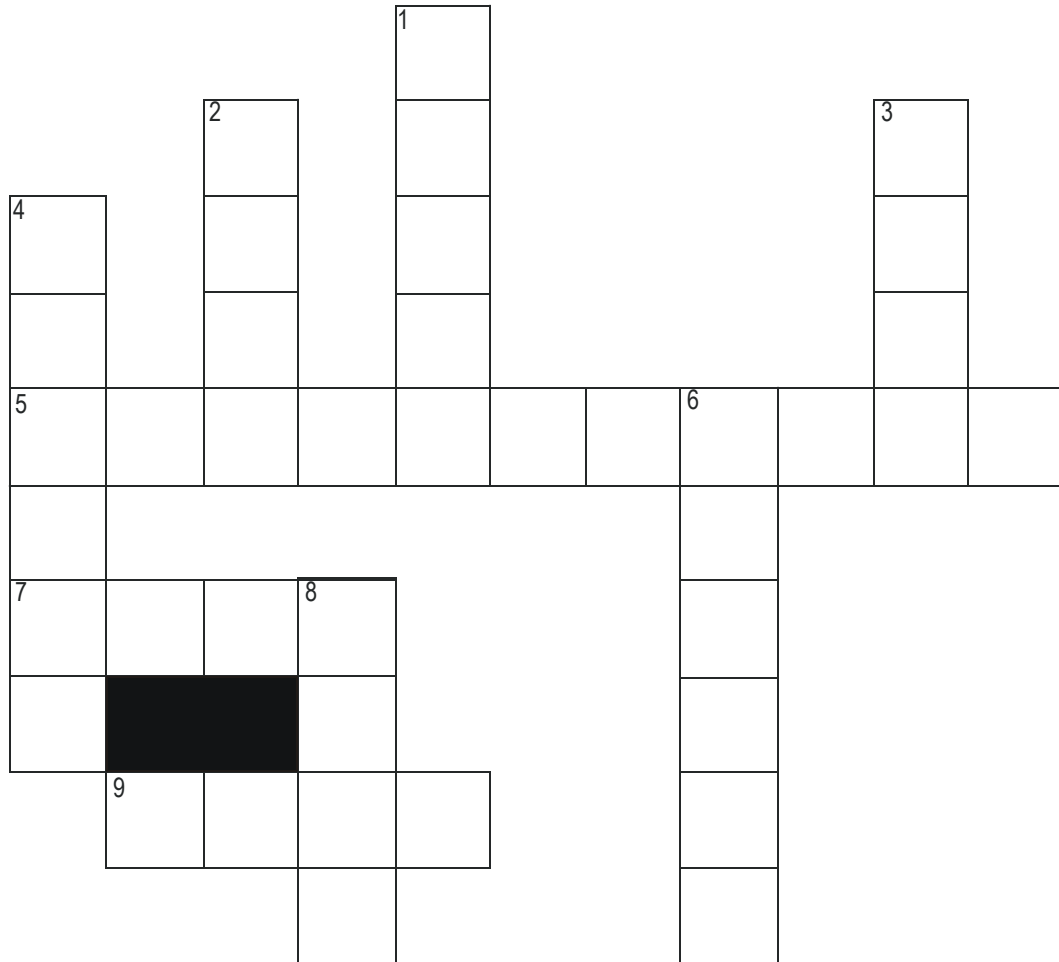

## ACROSS

5. The energy we use to run many machines.
7. Sugars give us energy to \_\_\_\_\_.
9. Energy doesn't disappear; it changes to another \_\_\_\_\_.

## DOWN

1. We use \_\_\_\_\_ energy to see.
2. We use energy to \_\_\_\_\_ from place to place.
3. Energy gives us \_\_\_\_\_ to keep us warm.
4. \_\_\_\_\_ is the ability to do work.
6. Energy is the power to make a \_\_\_\_\_.
8. Energy is the ability to do \_\_\_\_\_.

# LIGHT AND HEAT

Draw an X on the objects that do NOT make light.  
Draw a circle around the objects that we use for light.  
Draw a square around the objects that we use for heat.

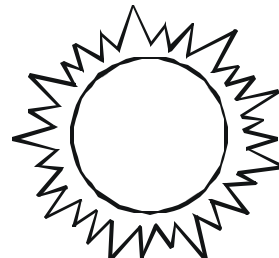
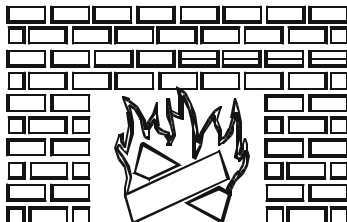
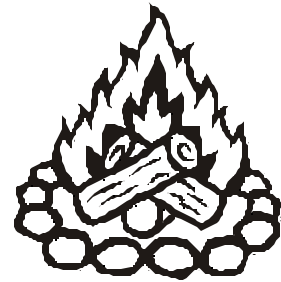
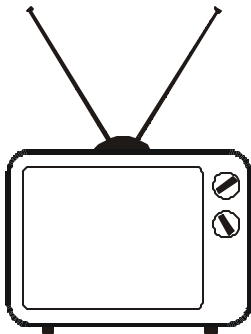
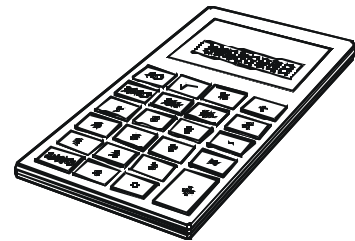
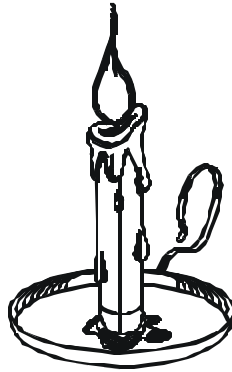
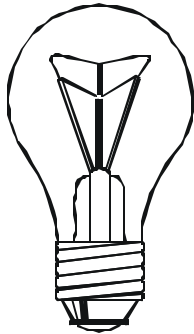
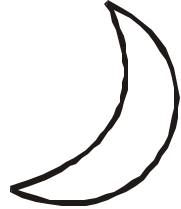
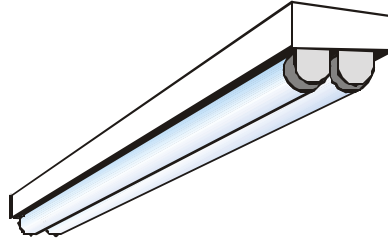
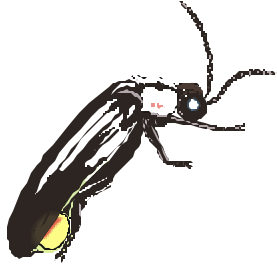

# GROWTH

Make an X on the objects that DO NOT use the sun's energy to grow.  
Color the things that need the sun's energy to grow.

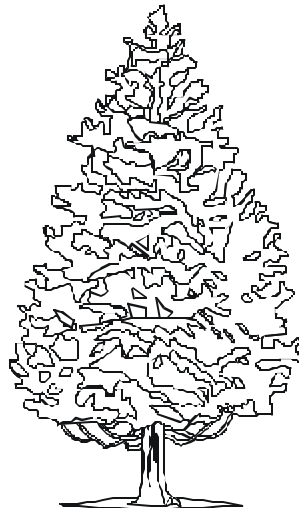
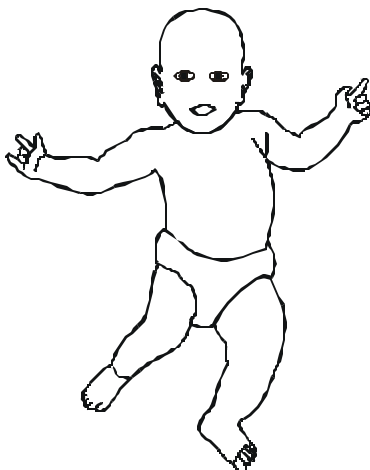
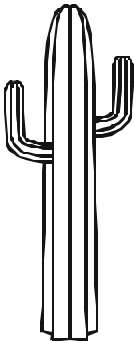
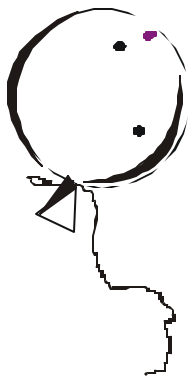
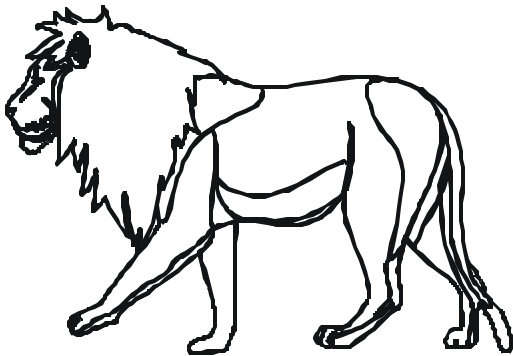
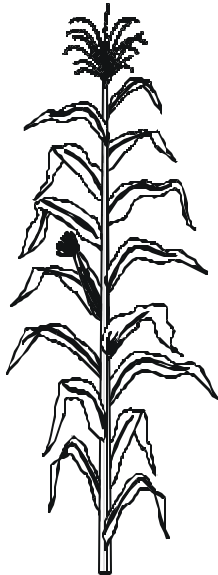
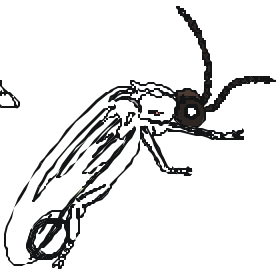
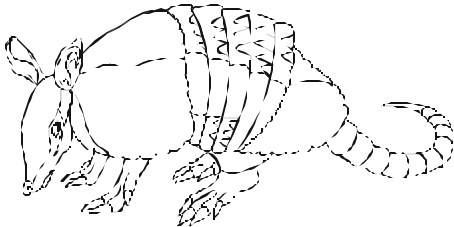
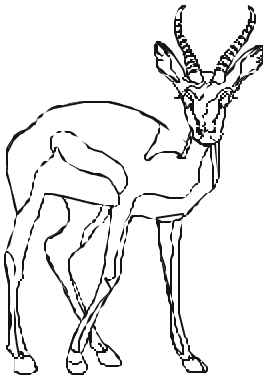
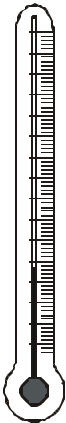

# MOTION

Make a circle around the objects that burn fuel to move.  
Color the objects that need people power to move.

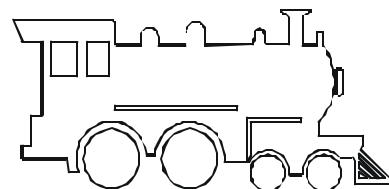
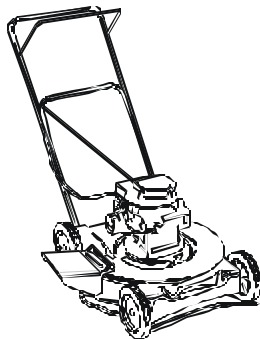
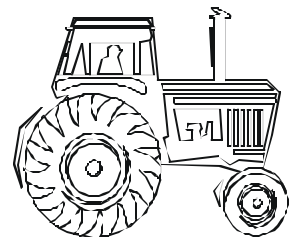
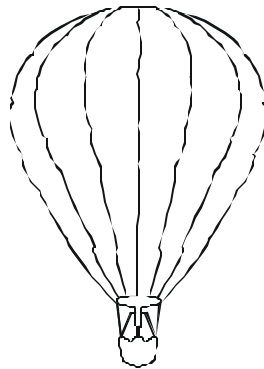
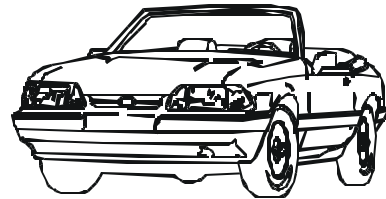
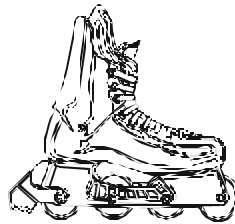
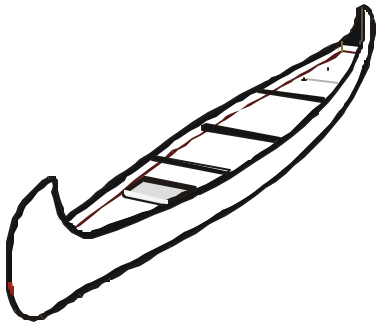
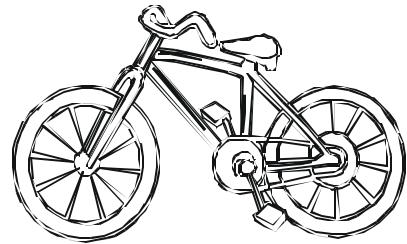
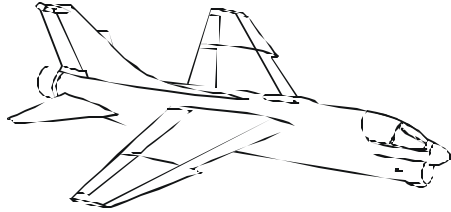

# ELECTRICITY

Draw a circle around the objects that use electricity from an outlet for energy.  
Draw a square around the objects that use electricity from a battery for energy.

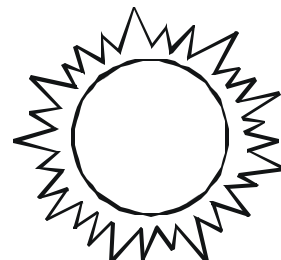
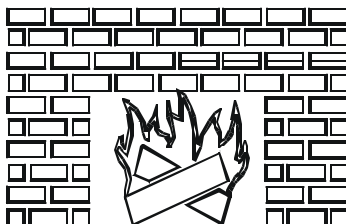
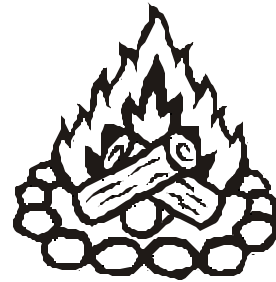
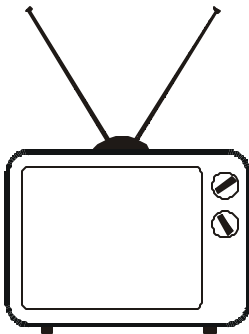
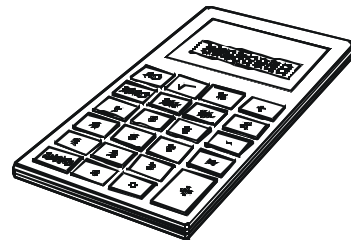
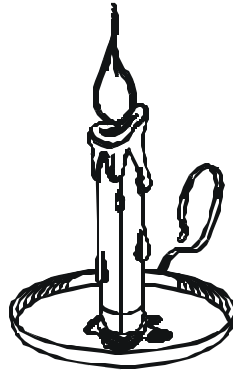
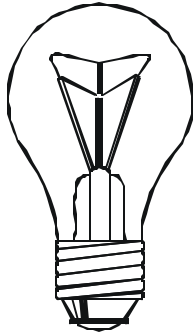
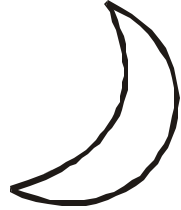
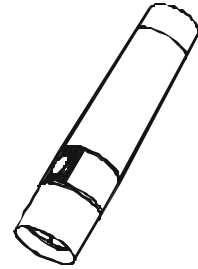
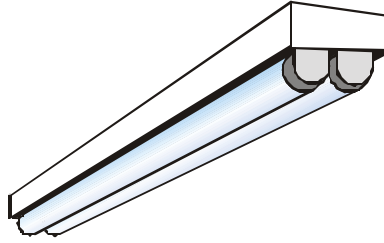
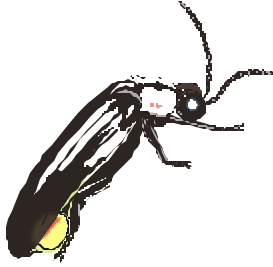

# YESTERDAY TO TODAY

Number the pictures from 1 to 6, from oldest energy pictures to newest.

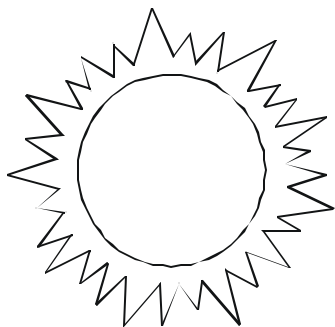
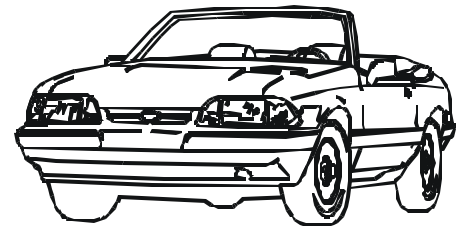
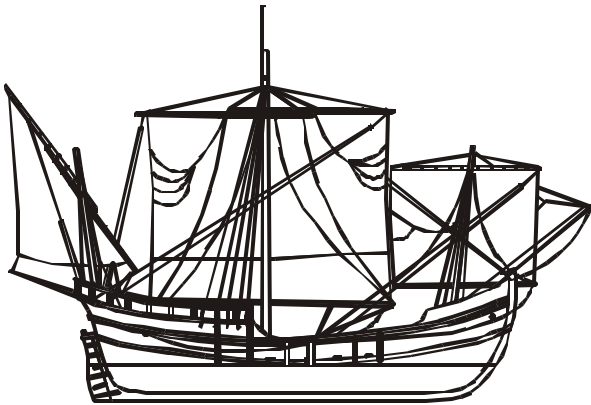
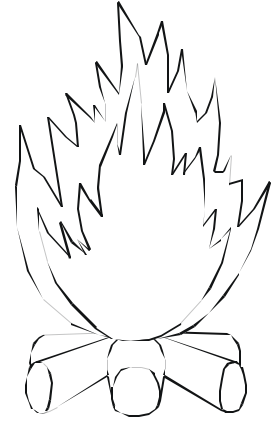
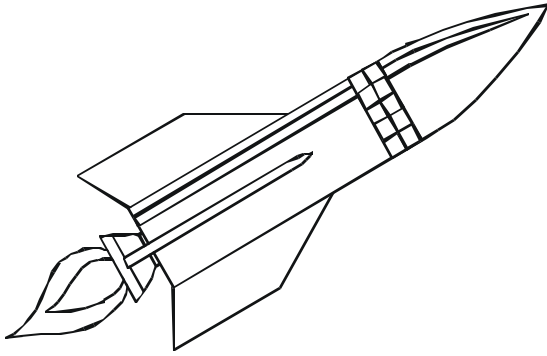

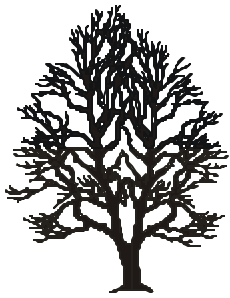

# BIOMASS

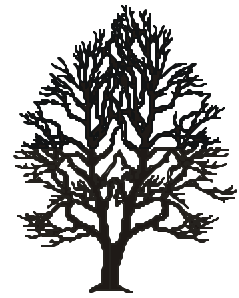

Fill in the blanks with the words in the box at the bottom of the page. Use each word only once.

1. Biomass is any \_\_\_\_\_ that was alive a short time ago.
2. Biomass is a \_\_\_\_\_ energy source, because we can always grow more plants.
3. We \_\_\_\_\_ most biomass to make heat.
4. We burn garbage in a \_\_\_\_\_ plant to make \_\_\_\_\_.
5. When biomass rots, it forms a \_\_\_\_\_ called \_\_\_\_\_ that we can use for energy.
6. Biomass can be turned into a liquid fuel like gasoline called \_\_\_\_\_.
7. Most of the biomass we use is \_\_\_\_\_.
8. Plants \_\_\_\_\_ energy from the sun in their roots and leaves.

renewable	ethanol	methane	wood	store
electricity	material	burn	gas	waste-to-energy

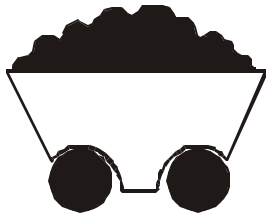

# COAL

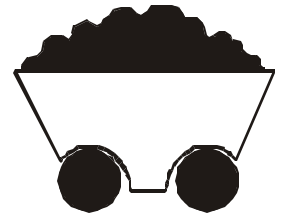

Fill in the blanks with the words in the box at the bottom of the page. Use each word only once.

1. Coal is called a \_\_\_\_\_ because it was made from plants millions of years ago.
2. Coal is \_\_\_\_\_; you can't make more in a short time.
3. When coal is near the surface, the earth is scraped off the coal in a \_\_\_\_\_.
4. To reach coal buried far underground, \_\_\_\_\_ are dug. This is called \_\_\_\_\_ mining.
5. Making the land usable again is called \_\_\_\_\_.
6. Coal is burned in a power plant to make \_\_\_\_\_.
7. Most coal is moved by \_\_\_\_\_ and \_\_\_\_\_.
8. Coal can \_\_\_\_\_ the air when it is burned.
9. Power plants use \_\_\_\_\_ to clean the smoke.

nonrenewable fossil fuel scrubbers shafts surface mine  
deep reclamation trains barges electricity pollute



# GEO THERMAL



Fill in the blanks with the words in the box at the bottom of the page. Use each word only once.

1. The Greek word for earth is \_\_\_\_\_.
2. The Greek word for heat is \_\_\_\_\_.
3. The center of the earth has an iron \_\_\_\_\_.
4. Hot melted rock is called \_\_\_\_\_.
5. The earth layer with rock and magma is the \_\_\_\_\_.
6. The shell of the earth is called the \_\_\_\_\_.
7. The heat inside the earth will always be there. We call geothermal a \_\_\_\_\_ energy source.
8. When hot water inside the earth comes to the surface, it can form \_\_\_\_\_.
9. A geothermal mountain called a \_\_\_\_\_ will sometimes pour out hot \_\_\_\_\_ with magma in it.
10. Geothermal power plants make \_\_\_\_\_.

crust	geo	magma	core	therme	electricity
hot springs	renewable	mantle	lava	volcano	



# HYDROPOWER

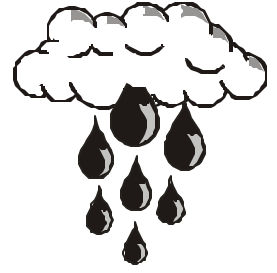

Fill in the blanks with the words in the box at the bottom of the page. Use each word only once.

1. Hydro means \_\_\_\_\_.
2. The movement of water between the earth and the clouds is called the \_\_\_\_\_.
3. When water turns into a gas it is called \_\_\_\_\_.
4. The force that moves water from high ground to lower ground is \_\_\_\_\_.
5. We can build a \_\_\_\_\_ across a river to control the flow of water and form a lake called a \_\_\_\_\_.
6. In a hydropower plant, the water flows through a tube called a \_\_\_\_\_ and spins a \_\_\_\_\_ to make \_\_\_\_\_.
7. The water cycle will keep water moving on the earth; we call hydropower a \_\_\_\_\_ energy source.

renewable	water	reservoir	gravity	penstock
water vapor	turbine	dam	water cycle	electricity



# NATURAL GAS



Fill in the blanks with the words in the box at the bottom of the page. Use each word only once.

1. Natural gas is called a \_\_\_\_\_ because it was made from plants and animals millions of years ago.
2. We can't make natural gas in a short time, so we say it is a \_\_\_\_\_ energy source.
3. The energy in natural gas came from the \_\_\_\_\_.
4. Natural gas is underground; we drill \_\_\_\_\_ to find it.
5. Decaying garbage makes a gas called \_\_\_\_\_.
6. We move natural gas in \_\_\_\_\_.
7. We add a smell like \_\_\_\_\_ to natural gas so we know if there is a leak.
8. \_\_\_\_\_ use natural gas for heat.
9. \_\_\_\_\_ use natural gas to make products.
10. Power plants \_\_\_\_\_ natural gas to make electricity.

pipelines	methane	nonrenewable	wells	burn
fossil fuel	sun	rotten eggs	factories	homes

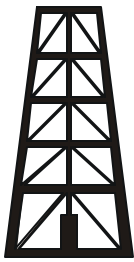

# PETROLEUM

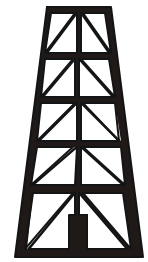

Fill in the blanks with the words in the box at the bottom of the page. Use each word only once.

1. Petroleum is called a \_\_\_\_\_ because it was made from plants and animals millions of years ago.
2. Another name for petroleum is \_\_\_\_\_ .
3. We can't make more petroleum in a short time, so we say it is a \_\_\_\_\_ energy source.
4. Some oil is underground; we \_\_\_\_\_ to find it.
5. Some oil is under the ocean; we use oil \_\_\_\_\_ to reach it and pump it to the surface.
6. We move petroleum by \_\_\_\_\_ and \_\_\_\_\_ .
7. After we pump petroleum from the ground, we send it to a \_\_\_\_\_ where some is made into \_\_\_\_\_
8. We \_\_\_\_\_ half the oil we use from other countries.
9. Burning petroleum products can cause air \_\_\_\_\_ .

gasoline	refinery	nonrenewable	ships	oil	rigs
fossil fuel	drill wells	pipelines	pollution	import	

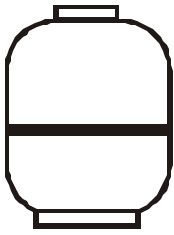

# PROPANE

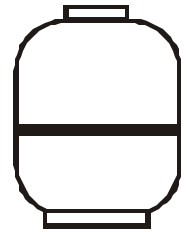

Fill in the blanks with the words in the box at the bottom of the page. Use each word only once.

1. Propane is called a \_\_\_\_\_ because it was formed from plants and animals millions of years ago.
2. We can't make more propane in a short time, so we say it is a \_\_\_\_\_ energy source.
3. Propane is found underground, mixed with \_\_\_\_\_ and \_\_\_\_\_.
4. At home, we use propane to fuel barbecue \_\_\_\_\_.
5. When we put propane gas under \_\_\_\_\_, it turns into a \_\_\_\_\_.
6. We store liquid propane in \_\_\_\_\_ and move it from place to place with \_\_\_\_\_.
7. Propane is called a \_\_\_\_\_ fuel because it is easy to move as a liquid.

portable	liquid	pressure	petroleum	natural gas
fossil fuel	nonrenewable	trucks	tanks	grills

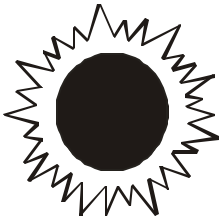

# SOLAR

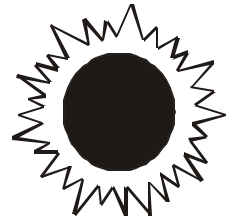

Fill in the blanks with the words in the box at the bottom of the page. Use each word only once.

1. We get solar energy from the \_\_\_\_\_, which is a big ball of \_\_\_\_\_.
2. Solar energy travels to the earth in \_\_\_\_\_.
3. The sun will always shine, so we say solar energy is a \_\_\_\_\_ energy source.
4. Plants \_\_\_\_\_ solar energy in their leaves.
5. Some solar energy is \_\_\_\_\_ so we can see.
6. Solar energy can turn into \_\_\_\_\_ when it hits things.
7. People use \_\_\_\_\_ on their roofs to heat their houses and water.
8. Solar calculators use \_\_\_\_\_ to turn energy from the sun into \_\_\_\_\_.

renewable	rays	sun	store	solar collectors
solar cells	electricity	heat	light	gas



# URANIUM



Fill in the blanks with the words in the box at the bottom of the page. Use each word only once.

1. Everything in the world is made of \_\_\_\_\_.
2. At the center of an atom is the \_\_\_\_\_. It is made of \_\_\_\_\_ and \_\_\_\_\_.
3. Moving around the nucleus are \_\_\_\_\_.
4. The energy stored in atoms is \_\_\_\_\_.
5. Uranium is buried underground. We can't make more, so we call uranium a \_\_\_\_\_ energy source.
6. Uranium atoms can be split; we call this \_\_\_\_\_.
7. When uranium atoms are split, energy is released as \_\_\_\_\_ and \_\_\_\_\_.
8. In a nuclear power plant, we split uranium atoms and use the heat to make \_\_\_\_\_.

nonrenewable   heat   nucleus   fission   atoms   radiation  
protons   nuclear energy   electrons   neutrons   electricity



# WIND



Fill in the blanks with the words in the box at the bottom of the page. Use each word only once.

1. The \_\_\_\_\_ shines on the earth. The \_\_\_\_\_ heats up faster than the water. The warm air over the land \_\_\_\_\_. The \_\_\_\_\_ air over the water moves in to take its place. This \_\_\_\_\_ is wind.
2. The sun will always shine; the wind will blow. We call wind a \_\_\_\_\_ energy source.
3. A \_\_\_\_\_ can capture the energy in the wind.
4. The spinning blades of a windmill turn a \_\_\_\_\_ to make \_\_\_\_\_.
5. Sometimes there are many windmills together to make electricity. This is called a \_\_\_\_\_.

renewable  
wind farm

sun  
cool

generator  
moving air

windmill  
electricity

rises  
land

# ENERGY SOURCE MATCHING

Draw a line from the energy source name to its symbol.

PETROLEUM

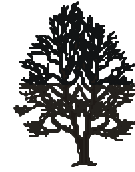

WIND



BIOMASS



URANIUM



PROPANE



SOLAR



GEOHERMAL



HYDROPOWER

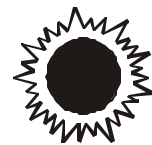

COAL

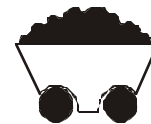

NATURAL GAS



# ENERGY SOURCE MATCHING

Draw a line from the energy source name to its definition.

PETROLEUM

Black rock burned to make electricity.

WIND

Energy from heat inside the earth.

BIOMASS

Energy from flowing water.

URANIUM

Energy from wood, waste and garbage.

PROPANE

Energy from moving air.

SOLAR

Energy from splitting atoms.

GEOHERMAL

Portable fossil fuel that is a gas.

HYDROPOWER

Fossil fuel for cars, trucks, and jets.

COAL

Fossil fuel gas moved by pipeline.

NATURAL GAS

Energy in rays from the sun.

# ENERGY SOURCE CROSSWORD

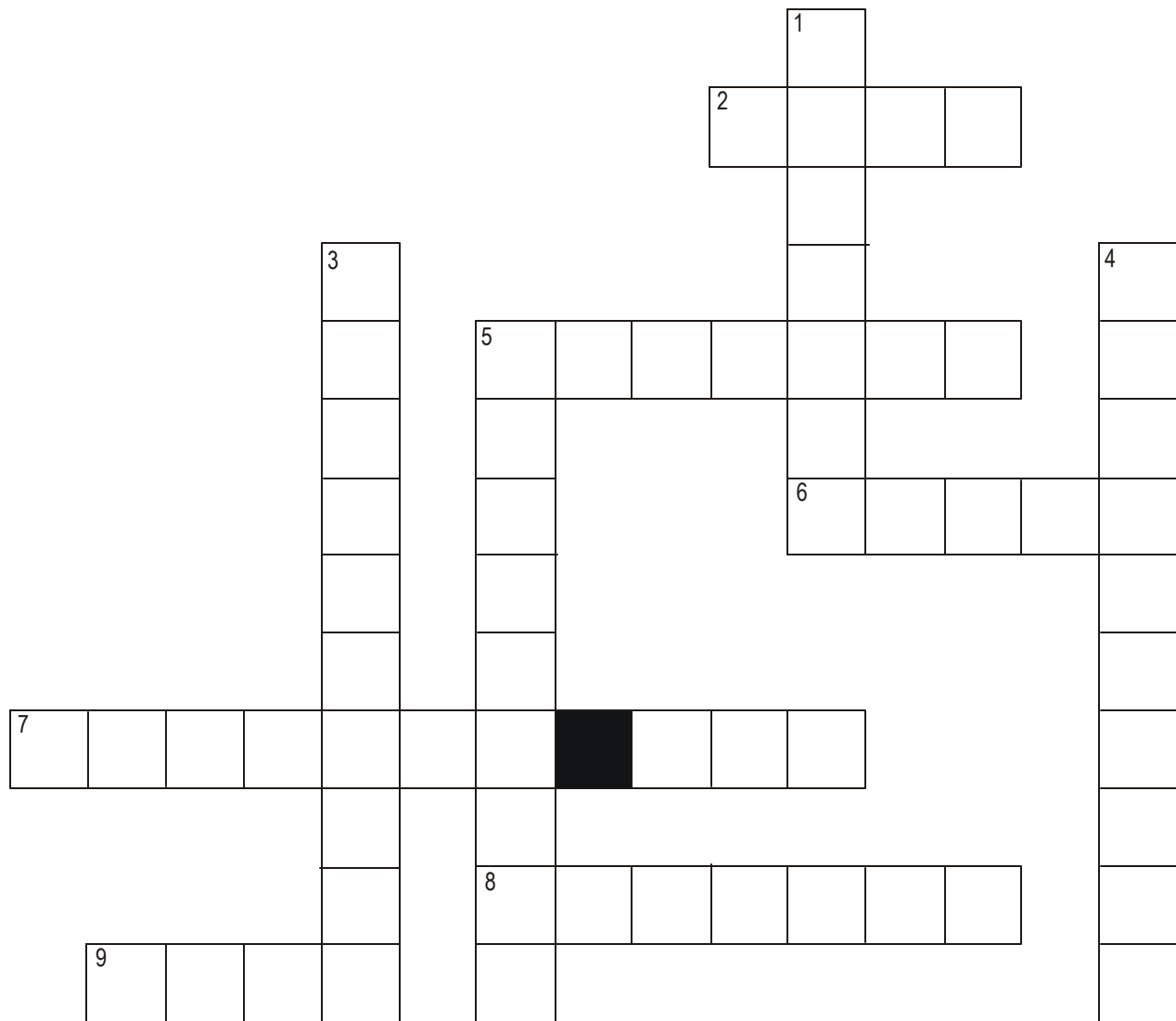

## ACROSS

2. The energy of moving air.
5. The portable gas.
6. Energy from the sun.
7. Gas moved in pipelines.
8. An atom of this element can split.
9. Black solid fossil fuel.

## DOWN

1. The energy in waste and wood.
3. Heat energy from inside the earth.
4. The energy in flowing water.
5. Liquid fossil fuel.

# RENEWABLE OR NONRENEWABLE?

Draw a  around the renewables and a  around the nonrenewables.

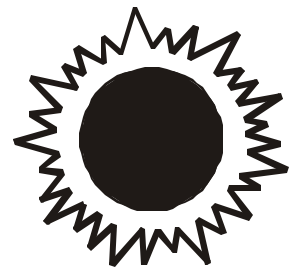
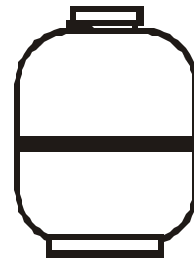
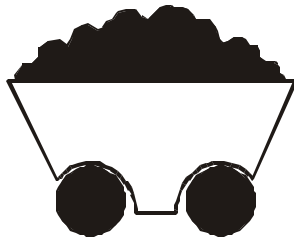
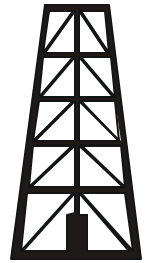
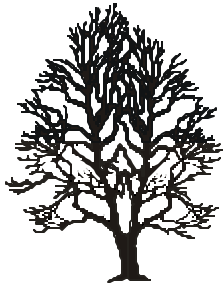

# RENEWABLES AND NONRENEWABLES

Make a pie chart in the circle showing how much of the energy we use comes from renewable energy sources and how much comes from nonrenewable sources.

PETROLEUM	38%
COAL	22%
NATURAL GAS	22%
URANIUM	8%
BIOMASS	4%
HYDROPOWER	3%
PROPANE	2%
GEOHERMAL, SOLAR, WIND	1%

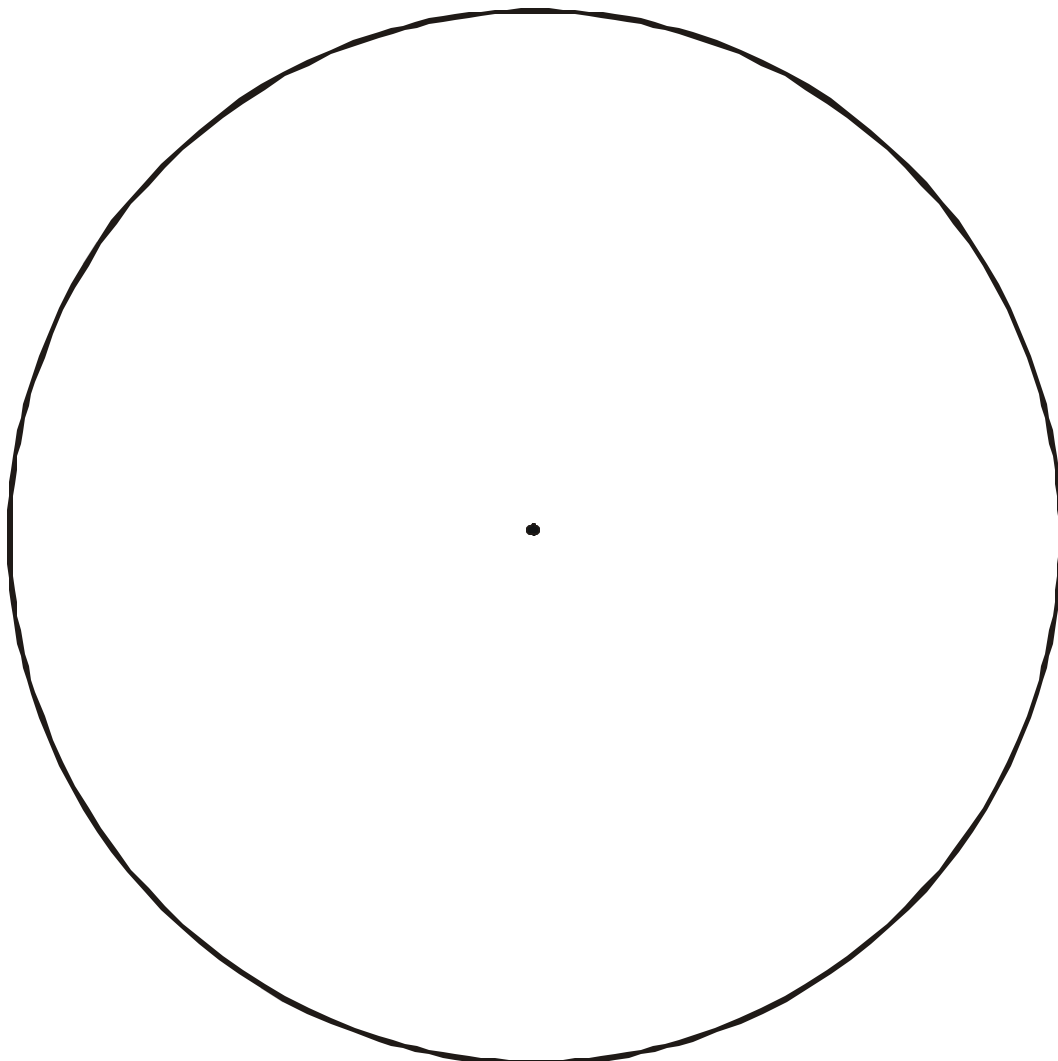

# WHERE WE GET THE ENERGY WE USE

Make a graph showing how much energy each source provides the United States. Write the names of the energy sources in the boxes at the bottom of the graph and fill in the columns to show the percentage each source provides.

PETROLEUM	38%
COAL	22%
NATURAL GAS	22%
URANIUM	8%
BIOMASS	4%
HYDROPOWER	3%
PROPANE	2%
GEOTHERMAL, SOLAR, WIND	1%

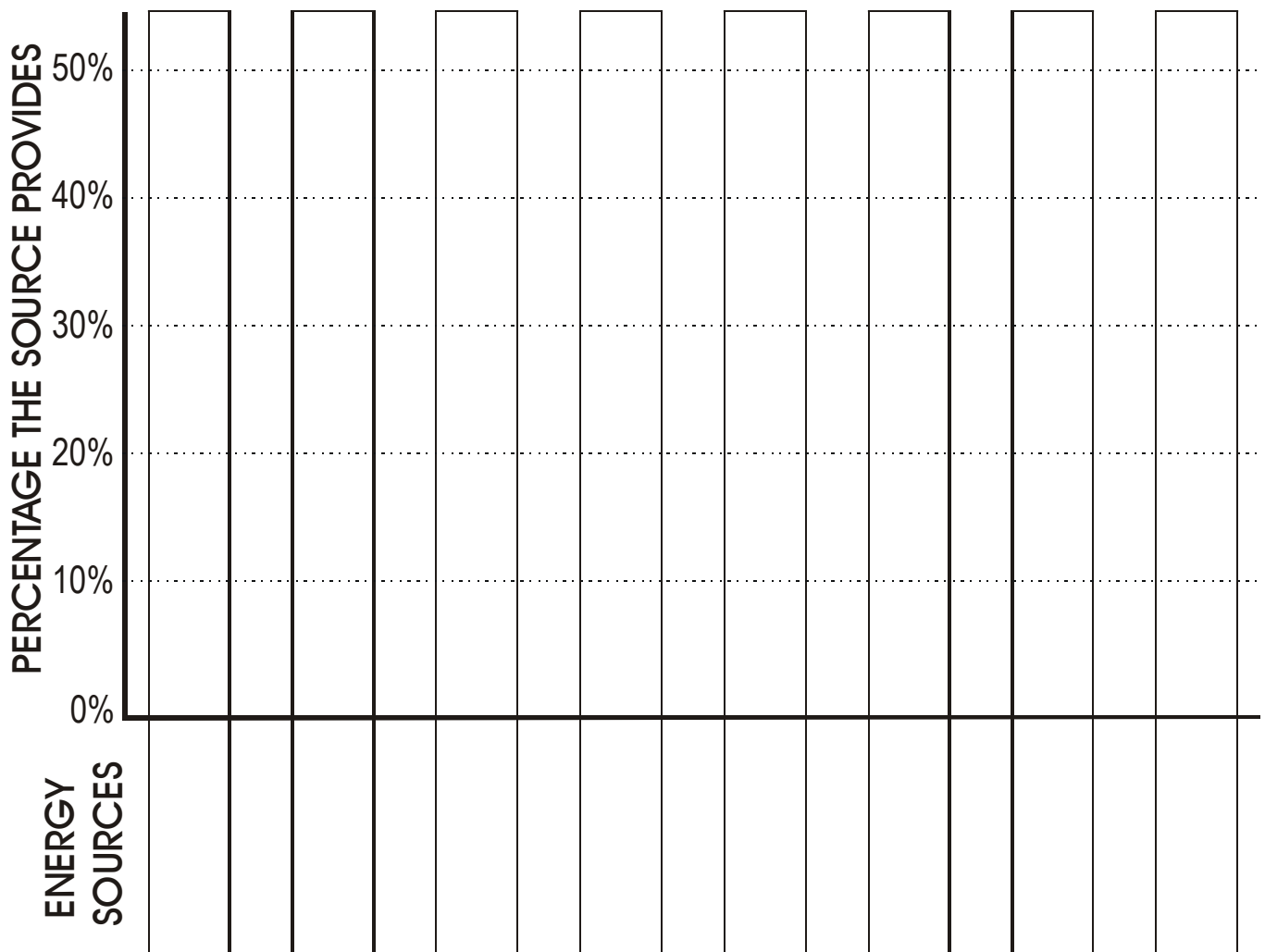

# PARTS OF AN ATOM

Write the names of the parts of an atom on the lines.

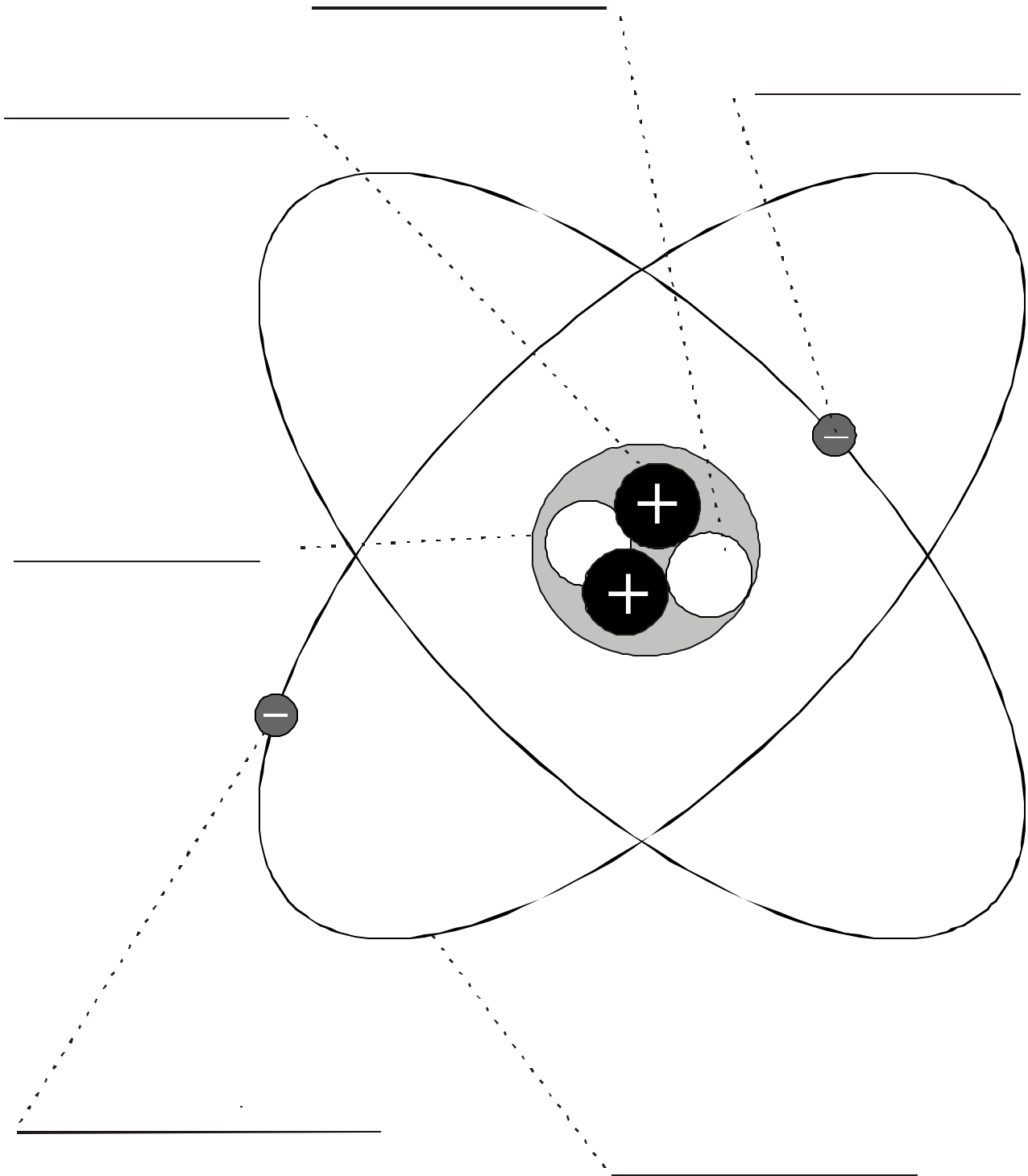

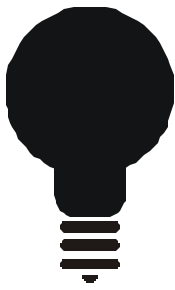

# ELECTRICITY 1

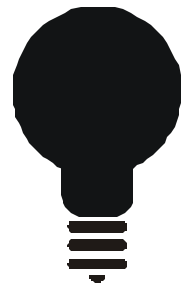

Fill in the blanks with the words in the box at the bottom of the page. Use each word only once.

1. In the center of an atom there are \_\_\_\_\_ that have a positive \_\_\_\_\_.
2. Electrons spin around the nucleus in \_\_\_\_\_ and have a \_\_\_\_\_ charge.
3. Opposite charges \_\_\_\_\_ each other.
4. \_\_\_\_\_ have North and South \_\_\_\_\_.
5. The North poles of magnets \_\_\_\_\_ each other.
6. Magnets have a force called a \_\_\_\_\_.
7. Magnets can push \_\_\_\_\_ out of their shells; moving electrons are called \_\_\_\_\_.
8. When electrons jump from one object to another, they are called \_\_\_\_\_.

attract	repel	electrons	electricity	magnets
poles	negative	protons	magnetic field	charge
static electricity		shells		

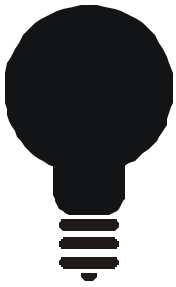

# ELECTRICITY 2

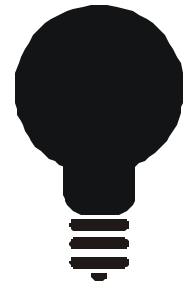

Fill in the blanks with the words in the box at the bottom of the page. Use each word only once.

1. A factory that makes electricity is a \_\_\_\_\_.
2. Power plants use \_\_\_\_\_ and \_\_\_\_\_ of copper wire to make electricity.
3. A giant wheel, called a \_\_\_\_\_, spins a coil of wire inside big magnets to produce a \_\_\_\_\_.
4. Many \_\_\_\_\_, such as coal, are used to spin the turbine and make \_\_\_\_\_.
5. The electricity flows in a big loop called a \_\_\_\_\_.
6. From the power plant, lots of electricity flows through large \_\_\_\_\_ held up by \_\_\_\_\_.
7. When electricity reaches the town, smaller wires, called \_\_\_\_\_ carry the electricity to \_\_\_\_\_ on \_\_\_\_\_.

fuels	turbine	power plant	magnets	circuit
electric poles	transmission lines	power towers	coils	
distribution lines	magnetic field	electricity	houses	

# MAGNETS

Does each set of magnets repel or attract? Circle the correct answer.



**attract or repel**



**attract or repel**

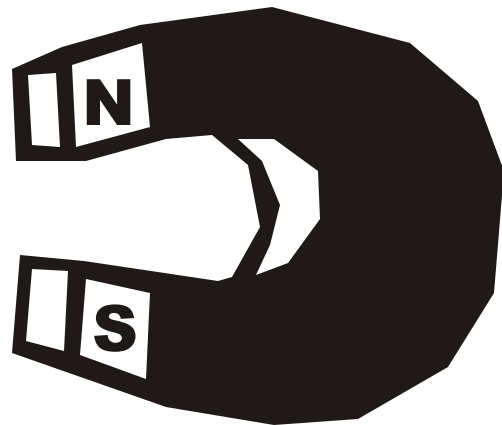
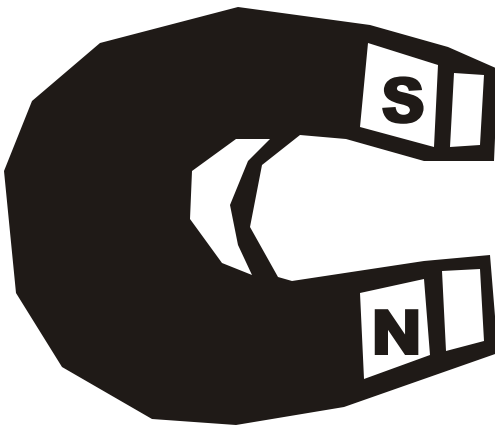

**attract or repel**

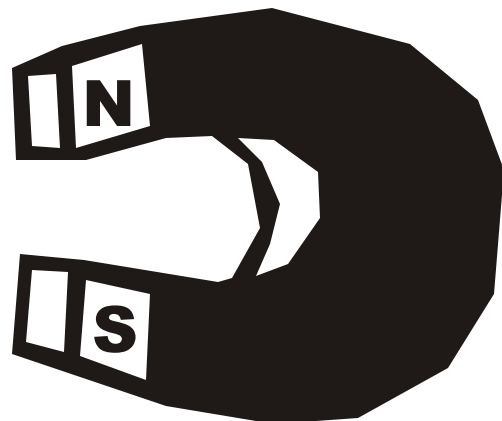
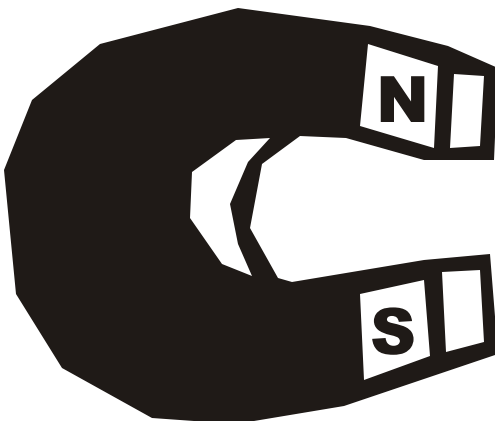

**attract or repel**

**The NEED Project  
8408 Kao Circle  
Manassas, VA 20110  
1-800-875-5029  
[www.NEED.org](http://www.NEED.org)**

