

SOLAR AT A GLANCE



Solar energy provided about 1% of all energy consumed in the United States 2024, mostly from photovoltaics.

WHAT IS SOLAR?

Solar energy is radiant energy that is produced by the sun. Every day the sun radiates, or sends out, an enormous amount of energy. The sun radiates more energy in one day than the world uses in one year. For this reason, we consider solar a renewable resource.

NUCLEAR FUSION

The process of fusion most commonly involves hydrogen isotopes combining to form a helium atom with a transformation of matter. This matter is emitted as radiant energy.

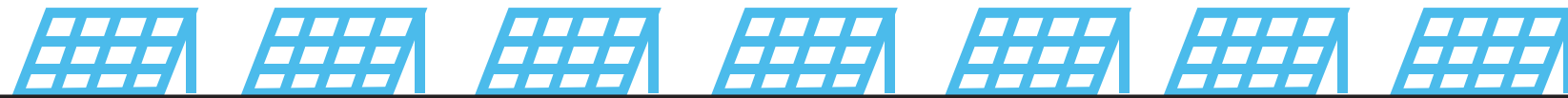
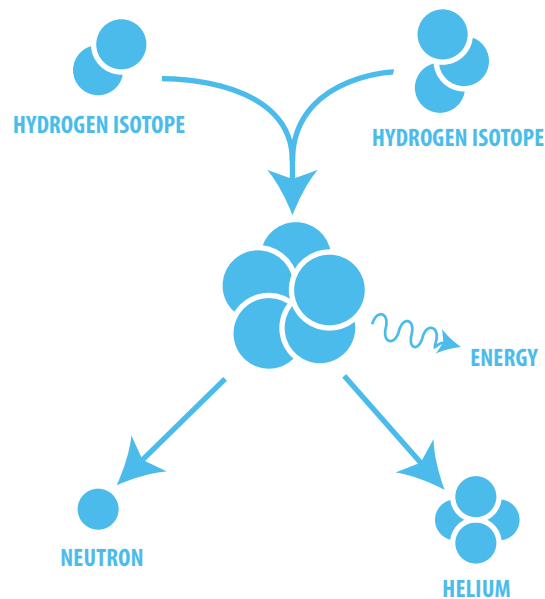

PHOTOVOLTAIC CELLS

Photovoltaic comes from the words photo meaning "light" and volt, a measurement of electricity. Sometimes photovoltaic cells are called PV cells or solar cells for short. These are the four steps that show how a PV cell is made and how it produces electricity.

⊕ PROTON — FREE ELECTRON ⊖ TIGHTLY-HELD ELECTRON ○ A LOCATION THAT CAN ACCEPT AN ELECTRON

1 A slab (or wafer) of pure silicon is used to make a PV cell. The top of the slab is very thinly diffused with an "n" dopant such as phosphorous. On the base of the slab a small amount of a "p" dopant, typically boron, is diffused. The boron side of the slab is 1,000 times thicker than the phosphorous side.

The phosphorous has one more electron in its outer shell than silicon, and the boron has one less. These dopants help create the electric field that motivates the energetic electrons out of the cell created when light strikes the PV cell. The phosphorous gives the wafer of silicon an excess of free electrons; it has a negative character. This is called n-type silicon (n = negative). The n-type silicon is not charged—it has an equal number of protons and electrons—but some of the electrons are not held tightly to the atoms. They are free to move to different locations within the layer. The boron gives the base of the silicon a positive character, because it has a tendency to attract electrons. The base of the silicon is called p-type silicon (p = positive). The p-type silicon has an equal number of protons and electrons; it has a positive character but not a positive charge.

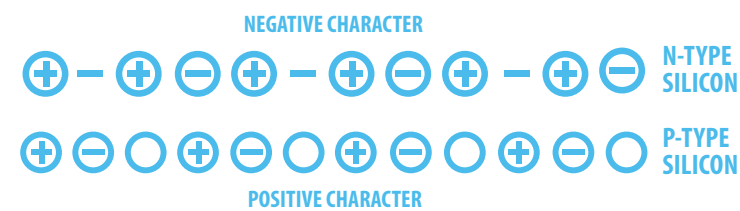

2 Where the n-type silicon and p-type silicon meet, free electrons from the n-layer flow into the p-layer for a split second, then form a barrier to prevent more electrons from moving between the two sides. This point of contact and barrier is called the p-n junction. When both sides of the silicon slab are doped, there is a negative charge in the p-type section of the junction and a positive charge in the n-type section of the junction due to movement of the electrons and "holes" at the junction of the two types of materials. This imbalance in electrical charge at the p-n junction produces an electric field between the p-type and n-type silicon

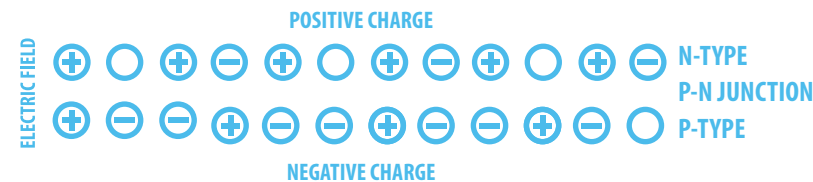

3 If the PV cell is placed in the sun, photons of light strike the electrons in the p-n junction and energize them, knocking them free of their atoms. These electrons are attracted to the positive charge in the n-type silicon and repelled by the negative charge in the p-type silicon. Most photon-electron collisions actually occur in the silicon base.

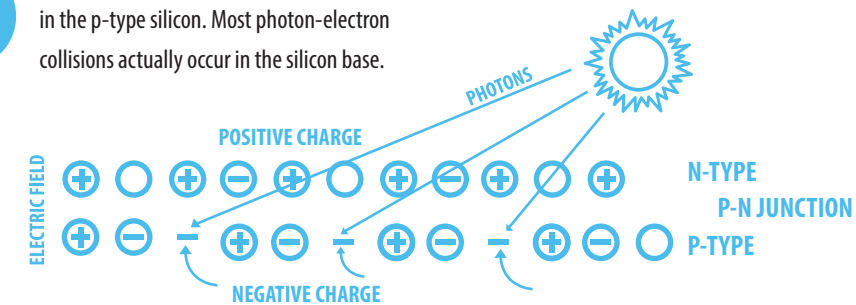

4 A conducting wire connects the p-type silicon to an electrical load, such as a light or battery, and then back to the n-type silicon, forming a complete circuit. As the free electrons are pushed into the n-type silicon they repel each other because they are of like charge. The wire provides a path for the electrons to move away from each other. This flow of electrons is an electric current that travels through the circuit from the n-type to the p-type silicon. In addition to the semi-conducting materials, solar cells consist of a top metallic grid or other electrical contact to collect electrons from the semi-conductor and transfer them to the external load, and a back contact layer to complete the electrical circuit

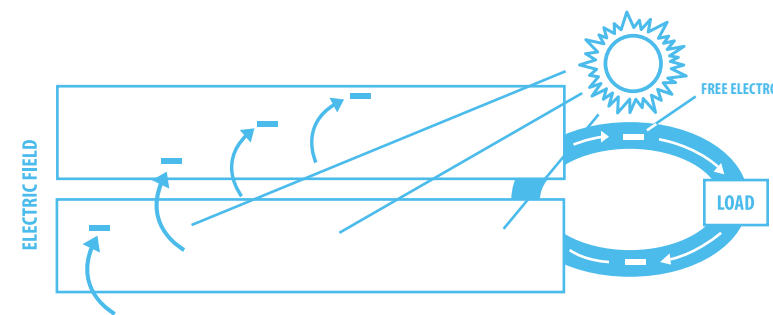

TOP SOLAR STATES



Data: Energy Information Administration